

# Tray/carton erectors

## TFS500 | Servo tray/carton erector

### Standard technical specifications

Speed: Up to 60 CPM

**Board size:** 500mm x 500mm board blank

**Board magazine stack height:** 1000mm

**Board loading height:** 1020mm

**Tray outfeed height:** 400mm

**Sample power consumption:** 11Kw, 32A/Ph, 400V, 3 Phase, N&E

**Air supply:** Up to 1.5 cfm @ 80 psi (5 bar)

**Net weight:** 500Kg

**Glue:** Preo hot melt glue system

**Specific components:** Rockwell Controls, SMC Pneumatics

**Colour:** RAL 7035 grey

### Board specification

**Tray/carton styles:** Low/High Walled, Shelf Ready, 90° and mitred corners and pizza

**Materials:** Fibre board and fluted corrugate

**FEFCO styles:** 0300, 0301, 0415 and 0420.

Can be adapted to suit most 03 and 04 styles

### Options

Vertical or horizontal card magazine

Nordson or Meler hot melt glue system

Crash lock system for hand erect trays

Inline and right angle discharge

Changepart or adjustable forming tools

On demand multiple size tray forming

Conveyors

Automatic or robotic tray/carton loading and closing

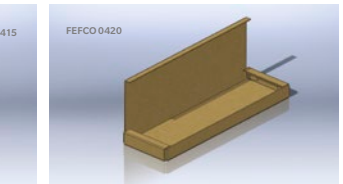
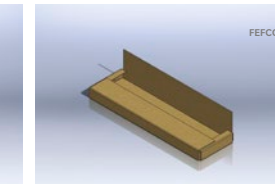
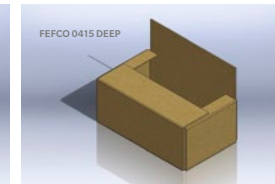
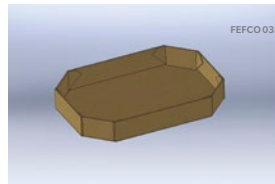
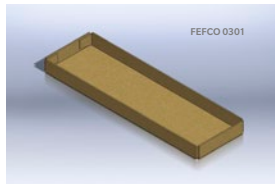
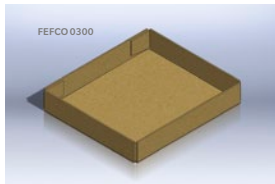
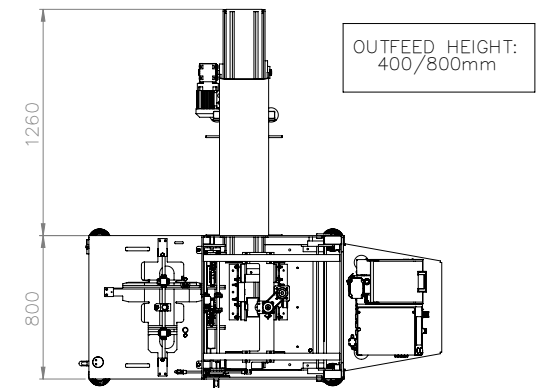
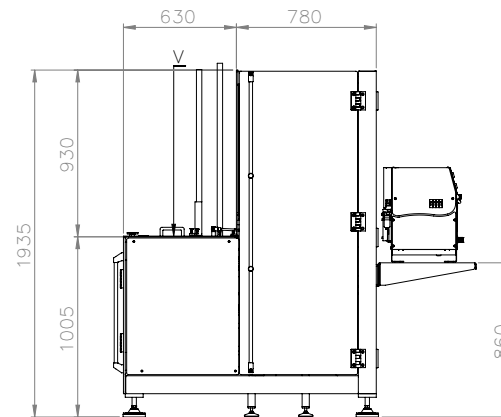

For more information, contact: WestRock Automated Packaging Systems  
Phone: +44.0.1502.713777 • E-mail: [aps.uk@westrock.com](mailto:aps.uk@westrock.com) • [www.linkxpackaging.com](http://www.linkxpackaging.com)

