



MATRIX SHRINK WRAPPER

MATRIX STANDARD TECHNICAL SPECIFICATIONS

- ◆ Speed: Up to 30/min
- ◆ Concept: High speed carton collating shrinkwrapper
- ◆ Max Film Width: 450mm
- ◆ Max Product Height: 300mm
- ◆ Feed: Inline
- ◆ Typical Outfeed Height: 900mm
- ◆ Sample Power Consumption: 30Kw, 32A/Ph, 440V, 3 Phase, N & E
- ◆ Sample Air Supply: Up to 4 cfm @ 80 psi (6 bar)
- ◆ Typical Net Weight: 2000Kg
- ◆ Specific Components: Rockwell Controls, SMC Pneumatics
- ◆ Colour: RAL 9007 Grey

PRODUCT HANDLING

- ◆ Typical Product Styles: cartons of fresh or frozen products

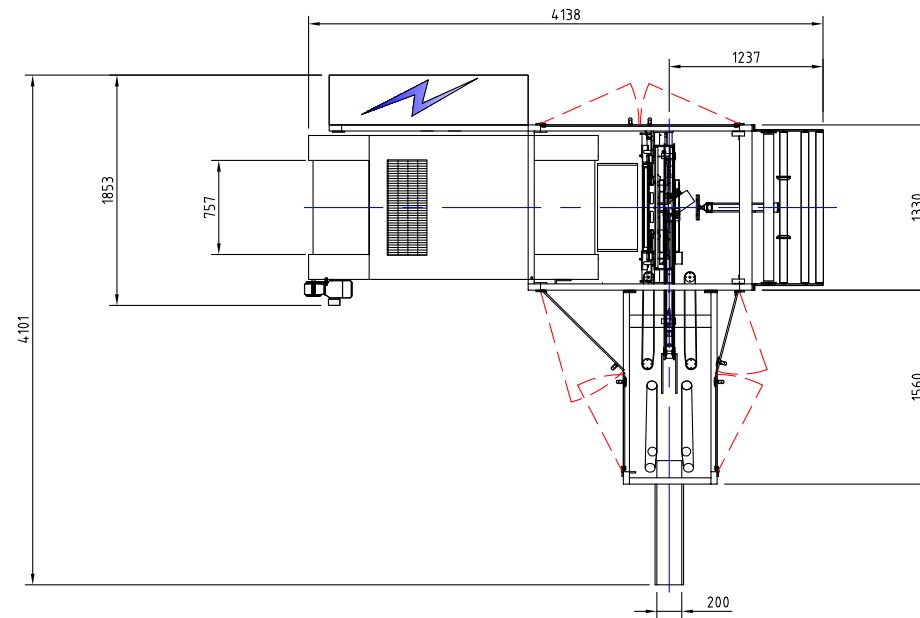
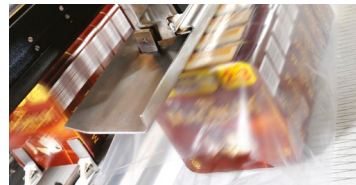

OPTIONS

- ◆ Automatic size change
- ◆ Stretch Wrap for reduced power consumption and sustainability
- ◆ Tear Strip for easy opening of finished pack
- ◆ Automatic film splice for continuous production flow
- ◆ Easy lace Automatic film splice with retractable film carriers
- ◆ Side seal units for fully enclosed packs
- ◆ Pack cooler after shrink tunnel
- ◆ Infeed and discharge conveyor systems of various mediums to suit product and floor space
- ◆ Stainless Steel construction
- ◆ Dairy specification construction
- ◆ Aerosol specification construction
- ◆ Right angle feed.

