



LP500 SHRINK WRAPPER

LP500 STANDARD TECHNICAL SPECIFICATIONS

- ◆ **Speed:** Up to 22/min
- ◆ **Concept:** Single size, with easy size change
- ◆ **Max Film Width:** 450mm
- ◆ **Max Product Height:** 300mm
- ◆ **Feed:** Inline
- ◆ **Typical Outfeed Height:** 900mm
- ◆ **Sample Power Consumption:** 26Kw, 53A/Ph, 440V, 3 Phase, N & E
- ◆ **Sample Air Supply:** Up to 16.8 cfm @ 80 psi (6 bar)
- ◆ **Typical Net Weight:** 1500Kg
- ◆ **Specific Components:** Rockwell Controls, SMC Pneumatics
- ◆ **Colour:** RAL 9007 Grey

PRODUCT HANDLING

- ◆ **Typical Product Styles:** cartons, bags, bottles, aerosols and tubs to name but a few

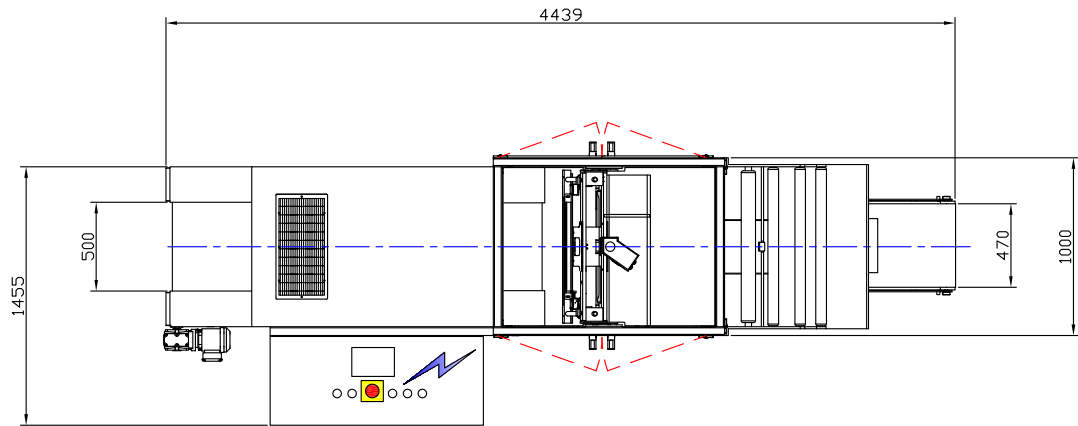
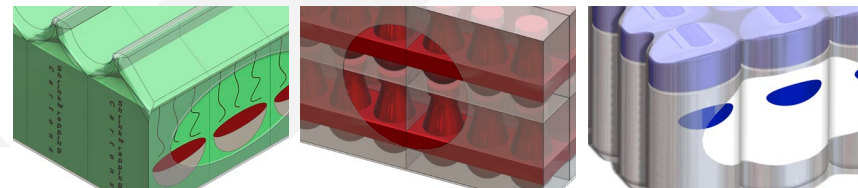

OPTIONS

- ◆ Box motion for increased throughput
- ◆ Collators to suit unsupported products include, product dividers, scrolls, starwheels, tierers, gating systems, race tracks etc.
- ◆ Stretch Wrap for reduced power consumption and sustainability
- ◆ Tear Strip for easy opening of finished pack
- ◆ Automatic film splice for continuous production flow
- ◆ Easy lace Automatic film splice with retractable film carriages
- ◆ Side seal units for fully enclosed packs
- ◆ Pack cooler after shrink tunnel
- ◆ Infeed and discharge conveyor systems of various mediums to suit product and floor space
- ◆ Stainless Steel construction
- ◆ Dairy specification construction
- ◆ Aerosol specification construction
- ◆ Right angle feed
- ◆ Inline feed.