



RP500 SHRINK WRAPPER

RP500 STANDARD TECHNICAL SPECIFICATIONS

- ◆ Speed: Up to 22/min
- ◆ Concept: Single size, with easy size change
- ◆ Max Film Width: 450mm
- ◆ Max Product Height: 300mm
- ◆ Feed: Right angle
- ◆ Typical Outfeed Height: 900mm
- ◆ Sample Power Consumption: 26Kw, 53A/Ph, 440V, 3 Phase, N & E
- ◆ Sample Air Supply: Up to 20.5 cfm @ 80 psi (6 bar)
- ◆ Typical Net Weight: 1500Kg
- ◆ Specific Components: Rockwell Controls, SMC Pneumatics
- ◆ Colour: RAL 9007 Grey

PRODUCT HANDLING

- ◆ Typical Product Styles: cartons, bags, bottles, aerosols and tubs to name but a few

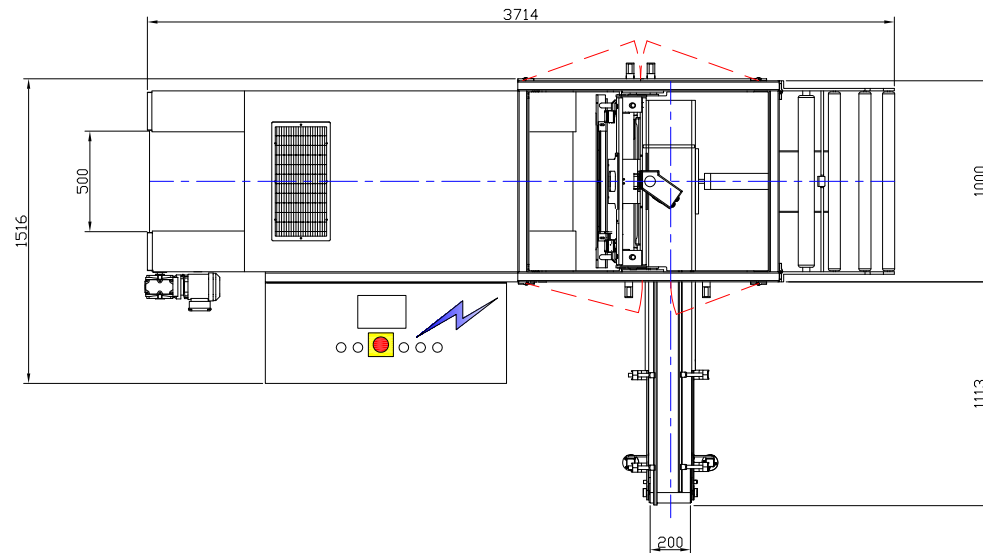

OPTIONS

- ◆ Box motion for increased throughput
- ◆ Collators to suit unsupported products include, product dividers, scrolls, starwheels, tierers, gating systems, race tracks etc.
- ◆ Stretch Wrap for reduced power consumption and sustainability
- ◆ Tear Strip for easy opening of finished pack
- ◆ Automatic film splice for continuous production flow
- ◆ Easy lace Automatic film splice with retractable film carriages
- ◆ Side seal units for fully enclosed packs
- ◆ Pack cooler after shrink tunnel
- ◆ Infeed and discharge conveyor systems of various mediums to suit product and floor space
- ◆ Stainless Steel construction
- ◆ Dairy specification construction
- ◆ Aerosol specification construction
- ◆ Right angle feed
- ◆ Inline feed.

