



# BX-F600-L

## FIXED FOOTPRINT WITH GLUE LID CLOSURE

### STANDARD TECHNICAL SPECIFICATIONS

- ◆ **Speed:** upto 10 Boxes per minute (dependent on box height)
- ◆ **Box Footprint:** Fixed
- ◆ **Closure:** Cut/Crimp/Fold/Glue/Lid
- ◆ **Min Footprint Size:** 320mm x 250mm
- ◆ **Max Footprint Size:** 750mm x 500mm
- ◆ **Typical Max Cut Length:** 450mm (dependant on box height and width)
- ◆ **Typical Infeed/Outfeed Height:** 700mm
- ◆ **Sample Power Consumption UK, EU, AU:** 21Kw, 30A/Ph, 50Hz, 400V, 3 Phase, N & E
- ◆ **Sample Power Consumption USA:** 21Kw, 30A/Ph, 60Hz, 208V, 3 Phase, N & E
- ◆ **Air Consumption:** Average 25 cfm @ 80-100 psi / Peak 42.5 cfm @ 80-100 psi @ 15 cycles/min
- ◆ **Net Weight:** 2000Kg
- ◆ **Specific Components:** Rockwell Control System
- ◆ Typical machine floorplan ref: LS-27486
- ◆ Touchscreen operator interface with management information and remote diagnostics
- ◆ Emergency stops and safety circuitry, fully CE marked
- ◆ Mild steel powder coated main framw
- ◆ Low maintenance servo drives used for precision motion control and remote diagnosis

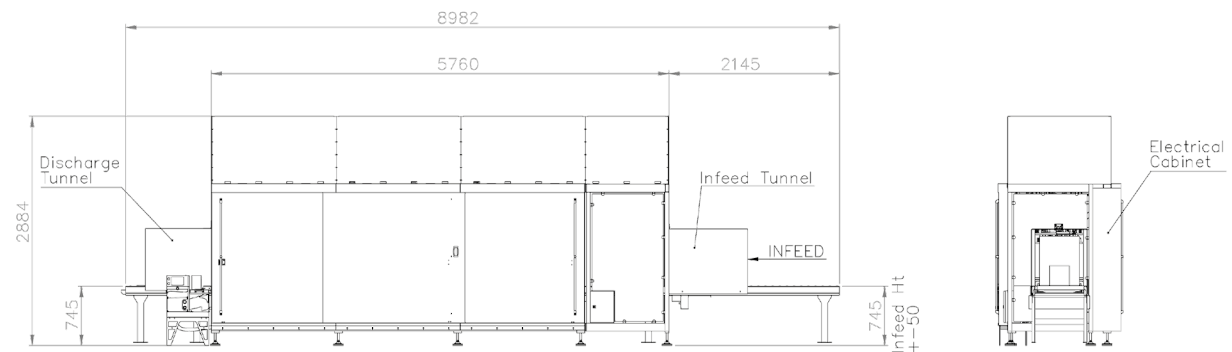
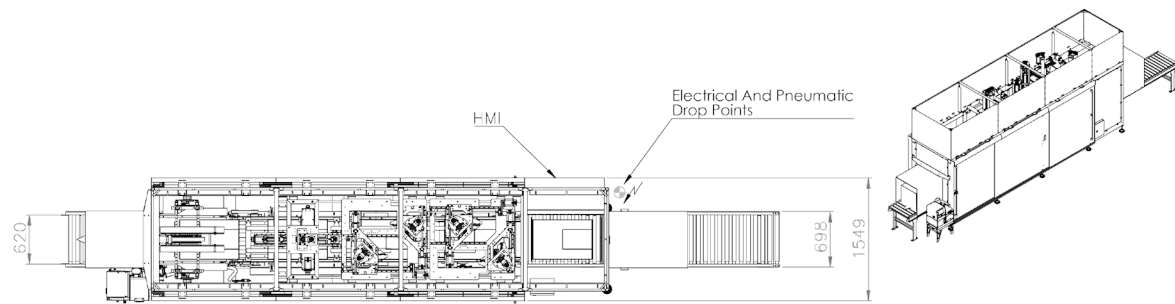

### BOX SPECIFICATION

- ◆ **Box Styles:** HSC or FEFCO 0200/0300/0301. Preferred 0200/HSC.
- ◆ **Materials:** B, C and E fluted corrugate of various grades typical, but not limited

### OPTIONS

- ◆ A range of options are available

### TYPICAL BOX INFEEED / OUTFEED

TYPICAL BOX IN

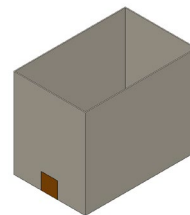

TYPICAL BOX OUT CUT/CRIMP/FOLD/GLUE/LID REDUCED VOLUME 1

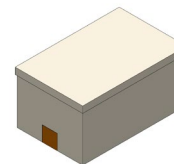

TYPICAL BOX OUT CUT/CRIMP/FOLD/GLUE/LID REDUCED VOLUME 2

